

---

## user guide

### dimmer

---

# PUSH-230V-AI

- 
- TECHNICAL FEATURES
  - MODES OF OPERATION
    - DEVICE POWER AND LOAD CONNECTION
  - WIRING OF THE PHYSICAL BUTTON IN CASE OF DISTURBANCES
  - ADVANCED FEATURES
    - PARAMETER SETUP MENU
  - PARAMETER CONFIGURATION
    - DIMMING TYPE CHANGE MENU
    - POWER-ON STATUS STORAGE MENU
    - TRANSFORMATION INTO RELAY MODE
    - TRANSFORMATION INTO DIMMER MODE
    - PARAMETER RESET

# PUSH-230V-AI

## PUSH input Phase cut output



22x45x40 mm  
weight: 25 gr

### TECHNICAL FEATURES

- Phase cut output dimmer with push input
- **AI edge output (default for mains voltage LED STRIP) or Trailing Edge mosfet output**
- Menu on button with possibility of setting: Minimum brightness level, Fade ON, Fade OFF, Logarithmic/linear dimming curve, phase cut type, storage and relay mode. Maximum intensity function on double click and night light on long press from off
- Output input terminals 0.12÷2.5 mm<sup>2</sup> (26÷14 AWG)
- Protection from: open circuit, voltage peaks, short circuit with internal 3A fuse
- **UL Printed Circuit Board**
- Power range: 80÷230V AC 50/60Hz
- Output power 110W at 110V, 220W at 220V, 230W at 230V
- Maximum resistive load 1A. See Table

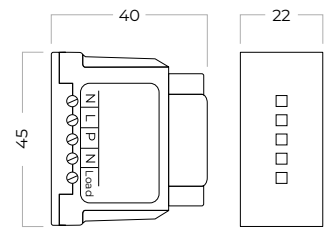

### SAFETY WARNINGS

- The device is not grounded
- Protection from accidental contact is guaranteed by the enclosure
- Storage temperature min: -40 max: 60° C
- Operating temperature min: -20 max: 50° C
- Thermal intervention: 150° C on uC
- Control Inputs: Non-isolated button x1 / Protection class: IP20
- Use only in dry environments

TYPE OF LOAD	MAXIMUM POWER
Incandescence - R	1A - 230W a 230V AC 1A - 110W a 110V AC
LED LINEARE - R CON PFC >0,9 e THD <10%	1A - 230W a 230V AC (max 20 lamps) 1A - 110W a 110V AC (max 20 lamps)
LED STRIP MAINS VOLTAGE - R	1A - 230W a 230V AC 1A - 110W a 110V AC
LED SWITCHING - RC CON PFC >0,9 e THD <10%	0.5A - 115W a 230V AC (max 10 lamps) 0.5A - 55W a 110V AC (max 10 lamps)
LED SWITCHING - RC CON PFC <0.9 e THD >10%	Dependent on peak load current value (e.g.: 0,1A per lamp, max 5 lamps)



**IMPORTANT:**  
the factory configured AI Edge dimmer is only compatible with VOLTAGE LED STRIPs MAINS or totally resistive loads.  
For use with other loads it is necessary to set it in advance in Trailing EDGE mode (p. 5) using a resistive test load.

- Do not connect inductive loads
- Do not connect to UPS with output other than Pure Sine Wave.

**IMPORTANT:** the lamps that can be controlled by a single dimmer must all be the same. All controlled loads must be declared DIMMABLE by the manufacturer.



CODE	VOLTAGE RANGE	MAX POWER	OUTPUT	INPUT	LOAD TYPE	PART NUMBER
<b>PUSH-230V-AI</b>	80÷230 V AC	230W	1	<b>PUSH</b>	monochrome	L704MC09T1A01

Maintenance: The appliance is maintenance-free. Use a dry cloth to clean it. The use of solvents or other aggressive substances should be avoided at all costs.

Disposal: at the end of its useful life, the product described in this data sheet is classified as waste from electronic equipment according to the European Directive 2012/19/EU (WEEE recast), implemented in Italy with Legislative Decree no. 49 of 14 March 2014, and cannot be disposed of as unsorted municipal solid waste. **Important:** Improper disposal of the product may cause serious harm to the environment and human health. For proper disposal, inquire about the collection and treatment methods provided by the local authorities.

## Modes of operation

### Device power and load connection

The PUSH-230V-AI dimmer must be connected according to the diagram shown in **FIG. 1**.

In particular:

- connect the power supply to the Input L and N terminals
- connect the load between the Output Load and N terminals
- connect a normally open button (N.O.) between N (Neutral) and the P terminal

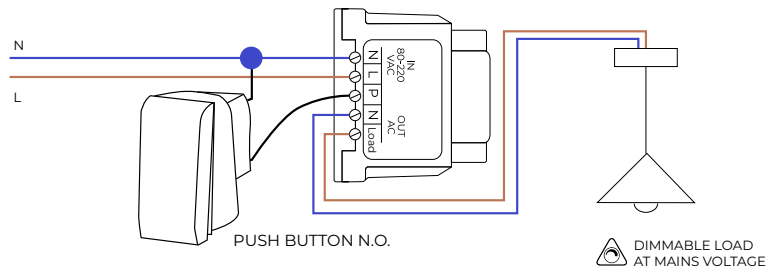
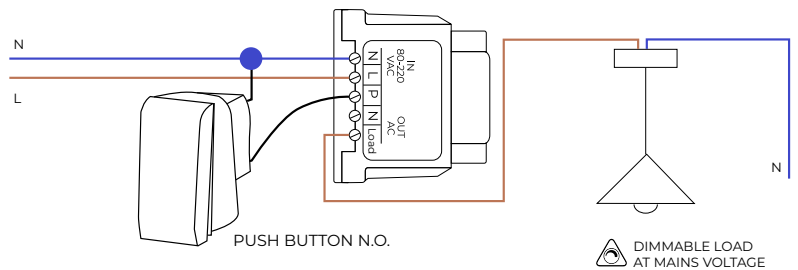

**FIG. 1** - PUSH-230V-AI 5 wire connection (recommended)

The PUSH-230V-AI dimmer can be connected according to the diagram shown in **FIG. 2**.

In particular:

- connect the power supply to the Input L and N terminals
- connect the load between the Load terminal of the dimmer and N (neutral) of the system
- connect a normally open button (N.O.) between N (Neutral) and the P terminal



**FIG. 2** - PUSH-230V-AI 4 wire connection

**nb:**  
In this configuration the load is not protected by the internal fuse of the PUSH-230V-AI dimmer

Once a normally open button has been connected as per FIGG. 1 or 2, it is possible to dim the load (incandescent lamps and/or dimmable phase-cut LED devices) according to the following method:

## PUSH interface operation

### Single Click (quick pressure <1sec)

- Switches the output on or off (ON/OFF).

### Double Click (quick pressure <1sec)

- Set maximum brightness (output = 100%).  
Fast maximum light mode.

### Long Press (prolonged pressure >1sec)

- If the dimmer is in the OFF state, set the output to the minimum value (default= 1%). Disturbance-free night mode.  
- If the dimmer is in the ON state, prolonged pressure allows the output to be dimmed (rise/fall).

## Wiring of the physical button in case of disturbances



### ATTENTION!

For the correct functioning of the dimmer it is important to keep the connection cable between the button and the dimmer as short as possible.

If malfunctions are found, particularly with the use of very long cables on the button or disturbed systems, it is recommended to install a monostable relay connected locally to the dimmer (FIG. 3).

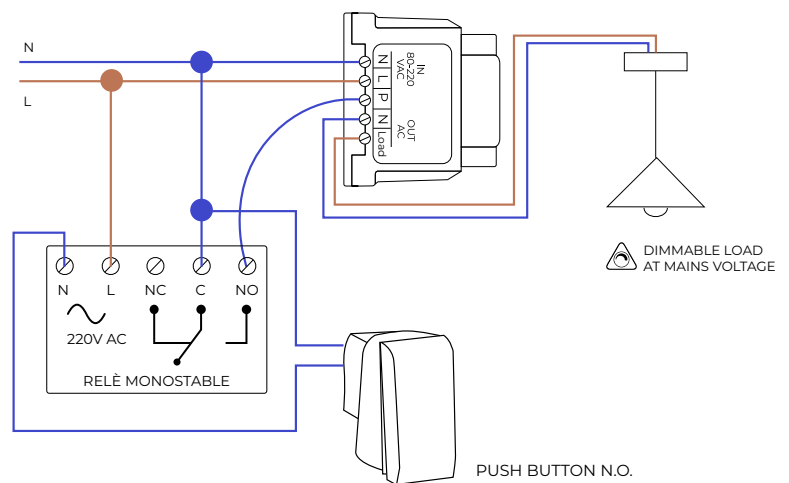
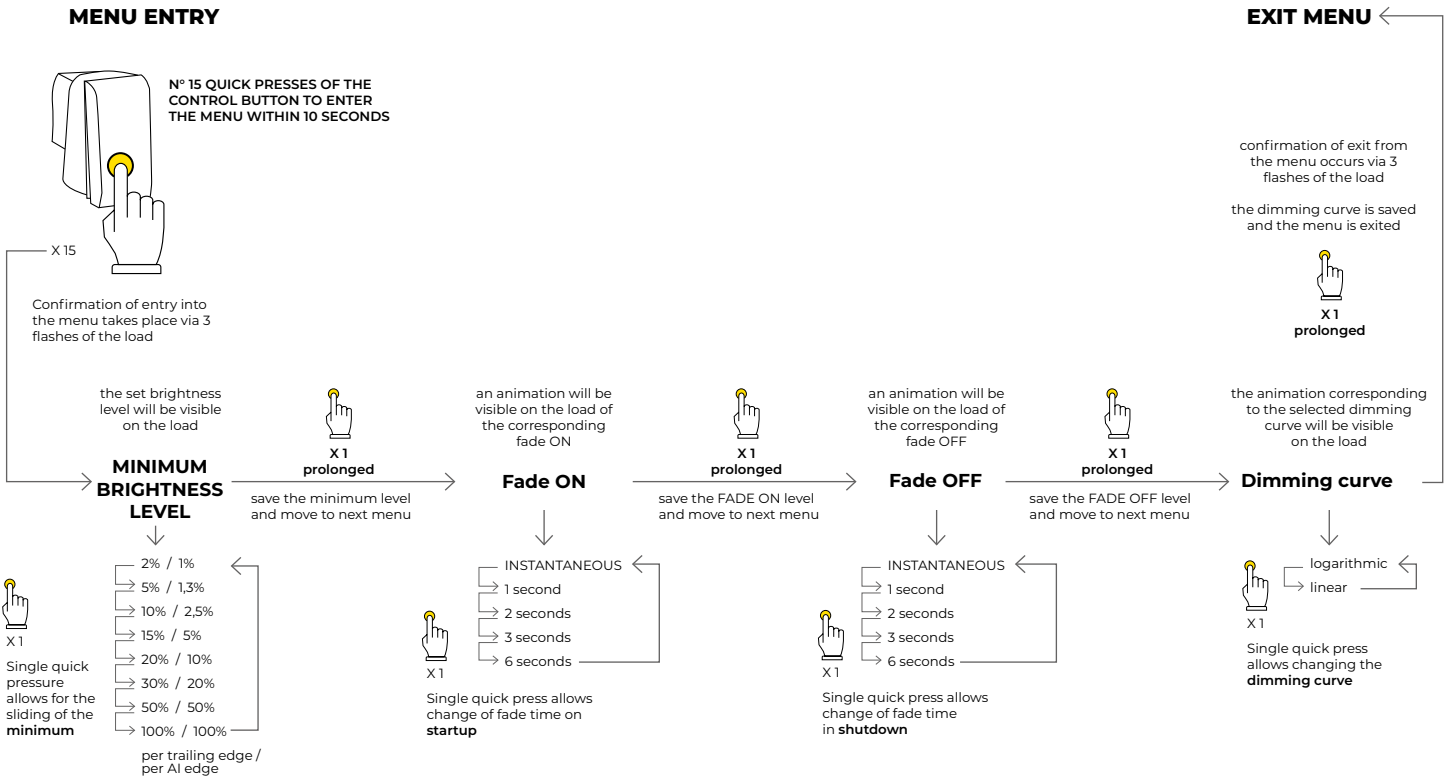

FIG. 3 - PUSH-230V-AI connection with relay

# Advanced features

## Parameter setup menu



Access with dimmer powered by 15 presses in rapid succession, within 10 seconds.  
 Entry into the menu is confirmed with 3 flashes.  
 A long press saves the parameter and the menu automatically passes to the next parameter.  
 Switching between the different parameters occurs with a quick press of the control button.

**First parameter:** Minimum level (8 values): each quick press changes the level.  
 There are different minimum levels for the two types of phase cutting:  
 For trailing edge, linear: 2%, 5%, 10%, 15%, 20%, 30%, 50%, 100%  
 For AI-Edge: 1%, 1.3%, 2.5%, 5%, 10%, 20%, 50%, 100%

**Second parameter:** *Fade ON time*, makes the switching on of the load “soft”.  
 Settable times: INSTANT, 1 second, 2 seconds, 3 seconds, 6 seconds.  
 Switching between the different times occurs with a quick press of the control button.  
 In this parameter the dimmer shows a cyclic simulation of a Fade ON (0%-100% in the set time).  
 A long press saves the Fade ON time and the menu automatically switches to the third parameter.

**Third parameter:** *Fade OFF time*, makes the switching off of the load “soft”.  
 Settable times: INSTANT, 1 second, 2 seconds, 3 seconds, 6 seconds.  
 Switching between the different times occurs with a quick press of the control button.  
 In this parameter the dimmer shows a cyclic simulation of a Fade OFF (100%-0% in the set time).  
 A long press saves the Fade OFF time and the menu moves on to the fourth parameter.

**Fourth parameter:** curve change (logarithmic - linear) allows each fast pressure to change the curve and simulate it.

Exit from the menu after the fourth parameter by holding it down (>800msec).  
 The dimmer confirms exit from the menu with 3 flashes.

# Parameter configuration

## Dimming type change menu

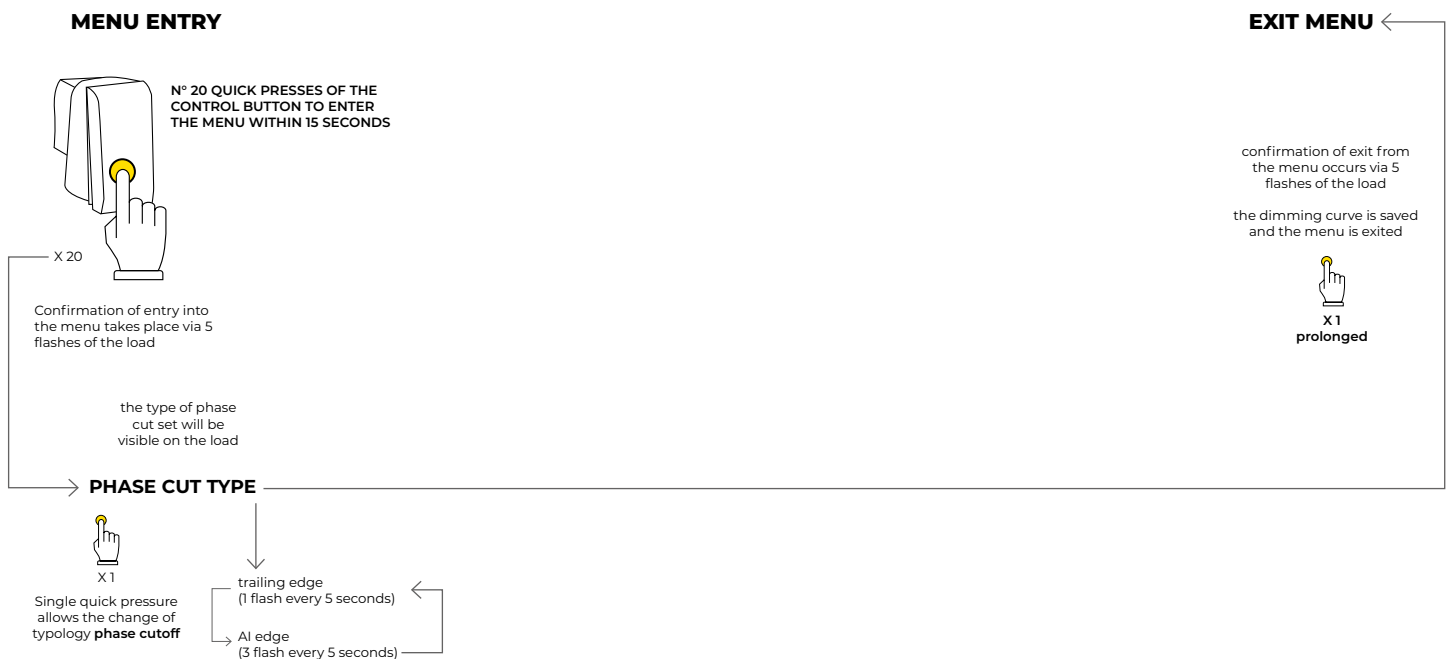

Access with dimmer powered by 20 presses in rapid succession, within 15 seconds.

**ATTENTION! Access this menu only with resistive loads or mains voltage LED STRIPs connected to the dimmer output. Entering this menu with RC connected loads could damage the dimmer or the load connected to it.** ⚠

Entry into the menu is confirmed with 5 flashes.

A long press saves the parameter and the menu automatically passes to the next parameter.

Switching between the different parameters occurs with a quick press of the control button.

**First parameter Phase cut:** Trailing edge – 1 flash every 5 seconds.

Phase cut: AI-Edge – 3 flashes every 5 seconds (**only compatible with Strip Led 230VAC**). ⚠

Exit from the menu after the fourth parameter by holding it down (>800msec).

The dimmer confirms exit from the menu with 5 flashes.

# Parameter configuration

## Power-on status storage menu



Access with dimmer powered by 25 presses in rapid succession, within 20 seconds.

Entry into the menu is confirmed with 7 flashes.

A long press saves the parameter and the menu automatically passes to the next parameter. Switching between the different parameters occurs with a quick press of the control button.

**First parameter:** Ignition state storage.

Restoration of the output state in the event of a power failure – 1 flash of the load every 5 seconds

Starting OFF: – 3 flashes of the load every 5 seconds

Start ON: – 5 flashes of the load every 5 seconds

Exit from the menu after parameter setup, by holding it down (>800msec).

The dimmer confirms exit from the menu with 7 flashes.

## Parameter configuration

### Transformation into relay mode

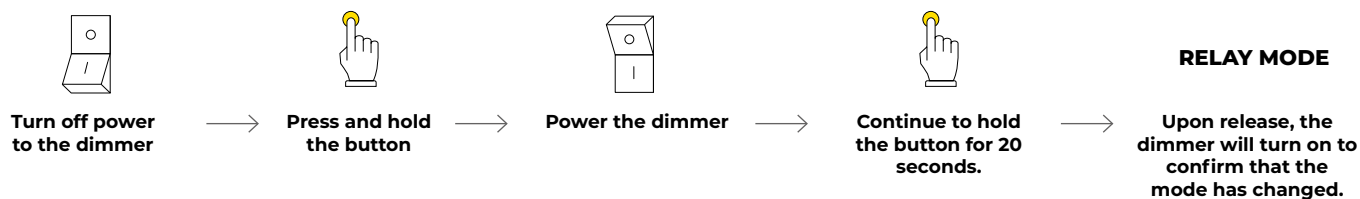

## Parameter configuration

### Transformation into dimmer mode

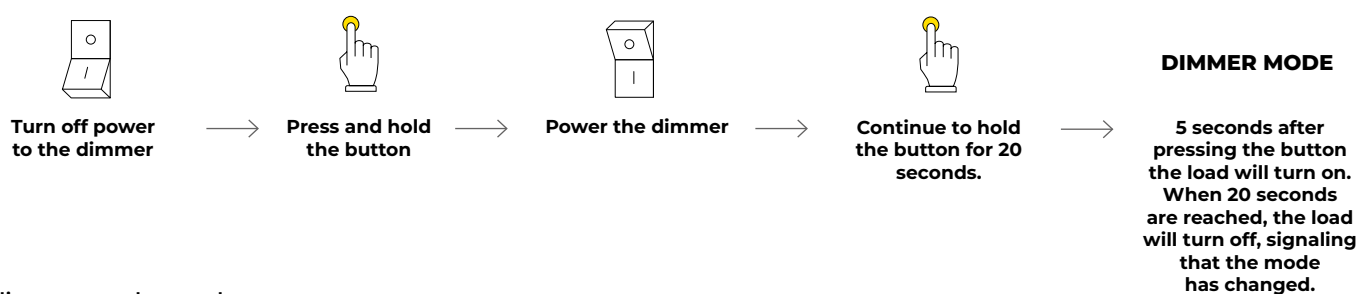

#### From dimmer to relay mode

With the dimmer turned off, hold down the button and power the dimmer.

Keep the button pressed for a further 20 seconds, during which the dimmer will have the load off.

When the button is released, the dimmer turns on the load. This signal confirms the passage into relay mode, thus becoming a silent impulse relay.

Everything is disabled except switching the load on and off upon rapid pressure (<200msec).

**nb: The menus are disabled.**

A quick press, double click or long press are always interpreted as a change in the output state.

#### From relay to dimmer mode

To return to dimmer mode, unplug the power and reset it with the control button by holding it for at least 20 seconds. 5 seconds after the power supply has been restored (with the button pressed) the dimmer turns on the load.

When 20 seconds are reached, the load is turned off to signal the change to Dimmer mode.

## Parameter configuration

### Parameter reset

If pressed for 40 seconds with the dimmer powered, the default parameters are reset.

Default parameters:

- Start on
- AI-Edge
- Logarithmic curve
- Memory enabled
- Fade IN 1 Sec
- Fade OFF 1 Sec